

C.S

LA-3154

**CIC-14 REPORT COLLECTION
REPRODUCTION
COPY**

**LOS ALAMOS SCIENTIFIC LABORATORY
OF THE UNIVERSITY OF CALIFORNIA ○ LOS ALAMOS NEW MEXICO**

**THE FABRICATION OF HOLLOW HEMISPHERES AND
CYLINDERS OF TUNGSTEN CARBIDE-6 W/O COBALT**

LOS ALAMOS NATIONAL LABORATORY
3 9338 00319 9709

LEGAL NOTICE

This report was prepared as an account of Government sponsored work. Neither the United States, nor the Commission, nor any person acting on behalf of the Commission:

A. Makes any warranty or representation, expressed or implied, with respect to the accuracy, completeness, or usefulness of the information contained in this report, or that the use of any information, apparatus, method, or process disclosed in this report may not infringe privately owned rights; or

B. Assumes any liabilities with respect to the use of, or for damages resulting from the use of any information, apparatus, method, or process disclosed in this report.

As used in the above, "person acting on behalf of the Commission" includes any employee or contractor of the Commission, or employee of such contractor, to the extent that such employee or contractor of the Commission, or employee of such contractor prepares, disseminates, or provides access to, any information pursuant to his employment or contract with the Commission, or his employment with such contractor.

Printed in USA. Price \$1.00. Available from the
Clearinghouse for Federal Scientific
and Technical Information,
National Bureau of Standards,
U. S. Department of Commerce,
Springfield, Virginia

LA-3154
UC-25, METALS, CERAMICS,
AND MATERIALS
TID-4500 (34th Ed.)

LOS ALAMOS SCIENTIFIC LABORATORY
OF THE UNIVERSITY OF CALIFORNIA LOS ALAMOS NEW MEXICO

REPORT WRITTEN: July 30, 1964

REPORT DISTRIBUTED: November 11, 1964

**THE FABRICATION OF HOLLOW HEMISPHERES AND
CYLINDERS OF TUNGSTEN CARBIDE-6 W/O COBALT**

Work done by:
Haskell Sheinberg
T. L. Herrera

Report written by:
Haskell Sheinberg

This report expresses the opinions of the author or authors and does not necessarily reflect the opinions or views of the Los Alamos Scientific Laboratory.

Contract W-7405-ENG. 36 with the U. S. Atomic Energy Commission

LOS ALAMOS NATL. LAB. LIBS.



3 9338 00319 9709

ABSTRACT

This report describes the details of die design, the powder preparation and loading, and the hot pressing operations employed to fabricate two 15.53-inch-O.D. x 10.20-inch-I.D. tungsten carbide-6 w/o cobalt hollow hemispheres with 3.95-inch-diameter polar cavities, and two 4.08-inch-diameter x 2.74-inch-long cylinders.

The metallographic structure of the starting powder and of a core from one of the hot pressed hemispheres is described.

ACKNOWLEDGEMENTS

The author wishes to acknowledge the suggestions of D. H. Schell in the design of the graphite dies, and the assistance of T. L. Herrera in the hot pressing operation and of Anne L. Waters for the typing of this report.

TABLE OF CONTENTS

	Page
Abstract	2
Acknowledgements	2
Introduction	5
Equipment	5
Materials	5
Procedure	9
Hot Pressing of Hemispheres	9
Hot Pressing of Cylinders	13
Discussion	13
Dies and Die Design	13
Temperature Measurement	15
Inspection and Sampling	15
Results	17

FIGURES

	Page
1. Tungsten Carbide Hemispheres, Drawing 19Y-29573, D3	6
2. 100-Ton and 250-Ton Capacity Hot Presses	7
3. WC-6 w/o Co Powder, Etched, 750X	8
4. Graphite Die Assembly for Pressing Cylinders , Drawing 26Y-75252, C1	10
5. Graphite Die Assembly for Pressing Hemispheres, Drawing 26Y-75251, D1	11
6. Pressure-Temperature Cycle for Hemispheres	12
7. Pressure-Temperature Cycle for Cylinders	14
8. Temperatures of Inner and Outer Graphite Die Cases	16
9. Photomicrographs of Core Samples	18
10. As Hot Pressed Hollow Hemisphere with Polar Cavity	19
11. Finish-Ground Hollow Hemisphere with Polar Cavity	20

TABLE

I. Chemical Analysis of Commercial WC-6 w/o Co Powder	8
---	---

INTRODUCTION

The Critical Assemblies Group at Los Alamos Scientific Laboratory required two WC-6 w/o Co hollow hemispheres fabricated in accordance with drawing 19Y-29573 D3 (Figure 1) and two cylinders to fill the polar cavities in the hemispheres for experimental purposes.

It was agreed that the required items would be fabricated by hot pressing and that the hemispheres would be pressed approximately 0.030 in. over-size on all dimensions to accommodate final grinding to drawing specifications by an outside vendor.

EQUIPMENT

The LASL-designed 250-ton hot press shown on the right in Figure 2 was employed for hot pressing the two hemispheres. The ram was activated with a Vickers hydraulic power unit Model 12057 and a Vickers Model 2304-E3 pump. An Ajax Electrothermic Co. 4-tap, 48-in.-O.D. induction coil coupled with a General Electric Co. 175-kW, 800-V, 960-cycle, air-cooled motor generator set provided induction heating of the graphite die assembly.

A Manley 60-ton hand-pumped shop press was employed for hot pressing the 4.085-in.-dia x 2.74-in.-long polar cavity cylinders. The inductive heating was supplied by a Westinghouse 100-kW, 800-V, 3,000-cycle, air-cooled motor generator set coupled to a 20-in.-O.D. Ajax Electrothermic Company 4-tap induction coil.

MATERIALS

The raw powder on hand was a commercial WC-6 w/o Co powder with a Fisher average particle size of 1.1 microns. Figure 3 is a photomicrograph of this powder. The powder as received had a bulk density of 4.0 g/cc and a tap density of 6.0 g/cc. The chemical analysis is shown in Table I.

To facilitate loading of the dies used for pressing hemispheres and to reduce overall punch movement during hot pressing, the powder was given a preliminary conditioning operation. It was isostatically pressed in

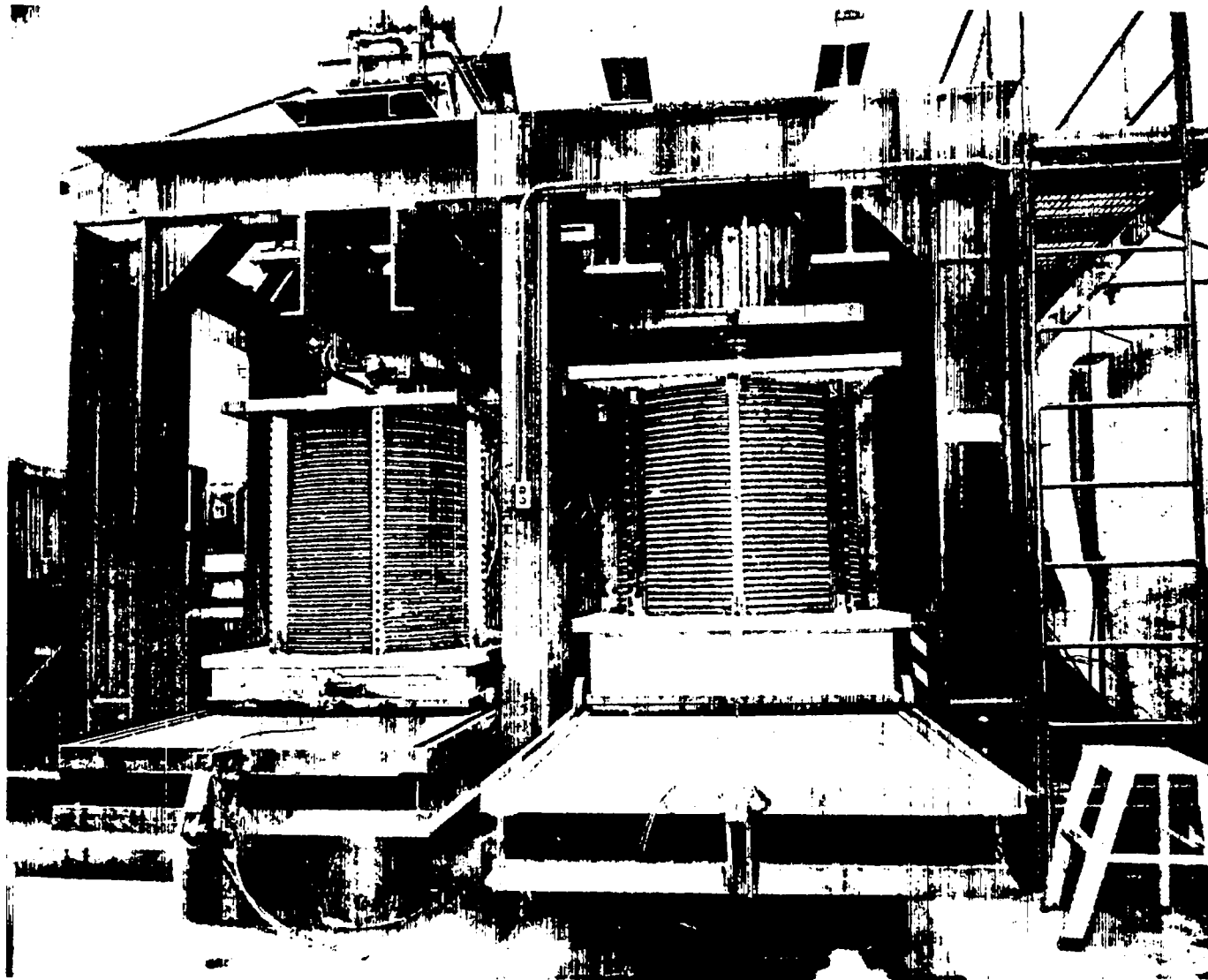

Figure 2 - 100-Ton and 250-Ton Capacity Hot Presses

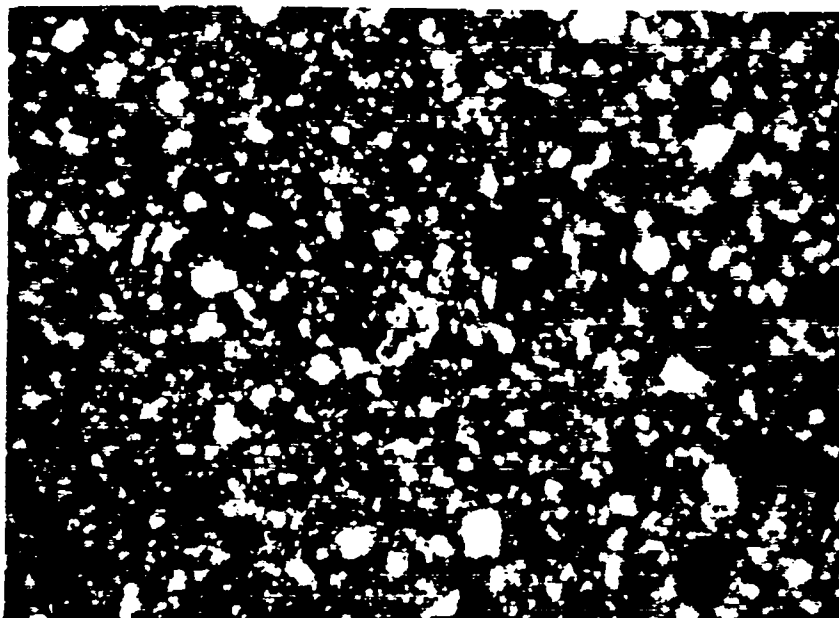

Figure 3 - WC-6 w/o Co Powder, Etched, 750X

TABLE I

CHEMICAL ANALYSIS OF COMMERCIAL WC-6 w/o Co POWDER

<u>Element</u>	<u>Quantity (ppm)</u>	<u>Element</u>	<u>Quantity (ppm)</u>
Li	10	Mn	30
Be	3	Fe	200
B	10	Ni	300
Na	30	Cu	10
Mg	10	Zn	100
Al	30	Sr	30
Si	200	Zr	30
K	30	Cb	300
Ca	100	Mo	100
Tl	30	Ag	3
V	100	Sn	50
Cr	30	Ba	10

Not detected: Cd, Pb, Bi
Co: 5.8 w/o

polyvinyl sacs at 30,000 psi to form cylinders 6.0 in. dia x 14.0 in. long. These cylinders were subsequently crushed in a Bico-Braun Chipmunk Crusher and screened through -35 mesh to provide a powder with a bulk density of 4.8 g/cc and a tap density of 6.5 g/cc.

The graphite die detailed in drawing 26Y-75252 (Figure 4) was employed for pressing the polar cavity cylinders. Great Lakes Carbon Co., grade H4LM graphite was utilized for pressing these two 4.08-in.-dia x 2.74-in.-long cylinders.

National Carbon Co. grade ATL graphite was employed in the first attempt to press a hemisphere; Great Lakes Carbon Co. grade MHLM-85, a multiple impregnated graphite, was successfully used for pressing the two hollow hemispheres.

PROCEDURE

Hot Pressing of Hemispheres

A graphite die assembly, detailed in drawing 26Y-75251, Rev. B (Figure 5) was designed and fabricated to press hollow hemispheres 0.060 in. larger in O.D. and 0.060 in. smaller in I.D. than the required finished dimensions shown in Figure 1. Additionally, a vertical stop was included in the die design to provide a 0.030-in. grinding stock at the equator.

All surfaces of die components which would contact the powder were coated with a dilute Aquadag solution. The center core (Figure 5, part 5) was inserted in the inner case (part 2), and the inner punch (part 4) was assembled on the center core. Wood dowels were used in the horizontal holes in the inner punch to position this part vertically on the center core so that the proper amount of powder would be loaded under the inner punch pressing area. Spacers (part 10) were inserted between the inner punch and the inner die case to maintain the inner parts of the assembly in concentric alignment during loading of the powder into the die.

Small portions of the 169.2-kg charge of conditioned powder were successively loaded into the die and tamped with 1.0-in.-dia wooden dowels. The spacers were removed, and the center punch was inserted without difficulty. The loaded die assembly was positioned in the hot press, and the charge was cold pressed by pressing separately on the inner and outer punches at 400 psi using appropriate spacers. The positions of the inner and outer punches relative to the die case were measured, and the assembly was covered with and surrounded by Thermax lampblack as a thermal insulator.

The die was heated inductively according to the graphed heat cycle (Figure 6) with an initial pressure of 350 psi on the outer punch.

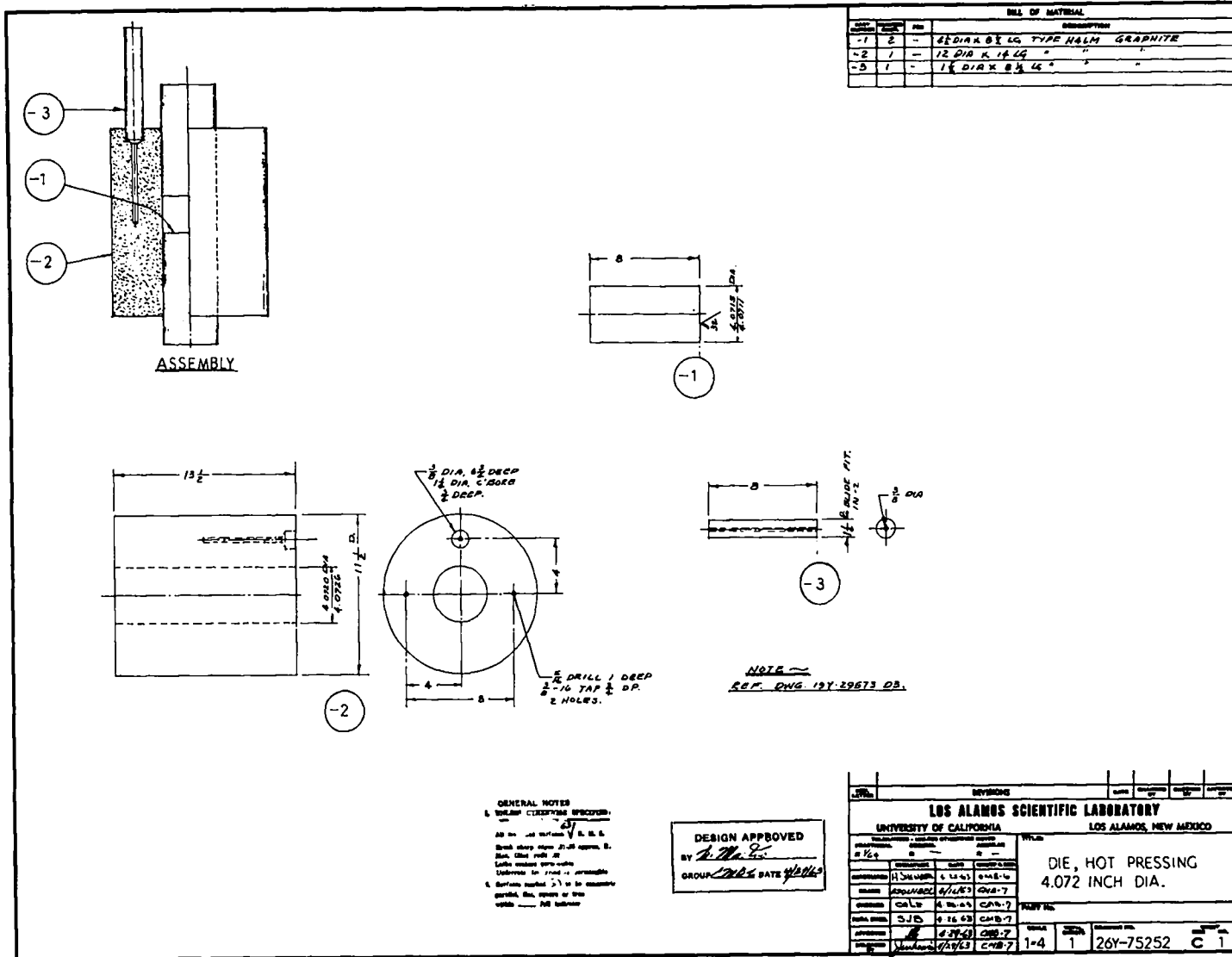

Figure 4 - Graphite Die Assembly for Pressing Cylinders

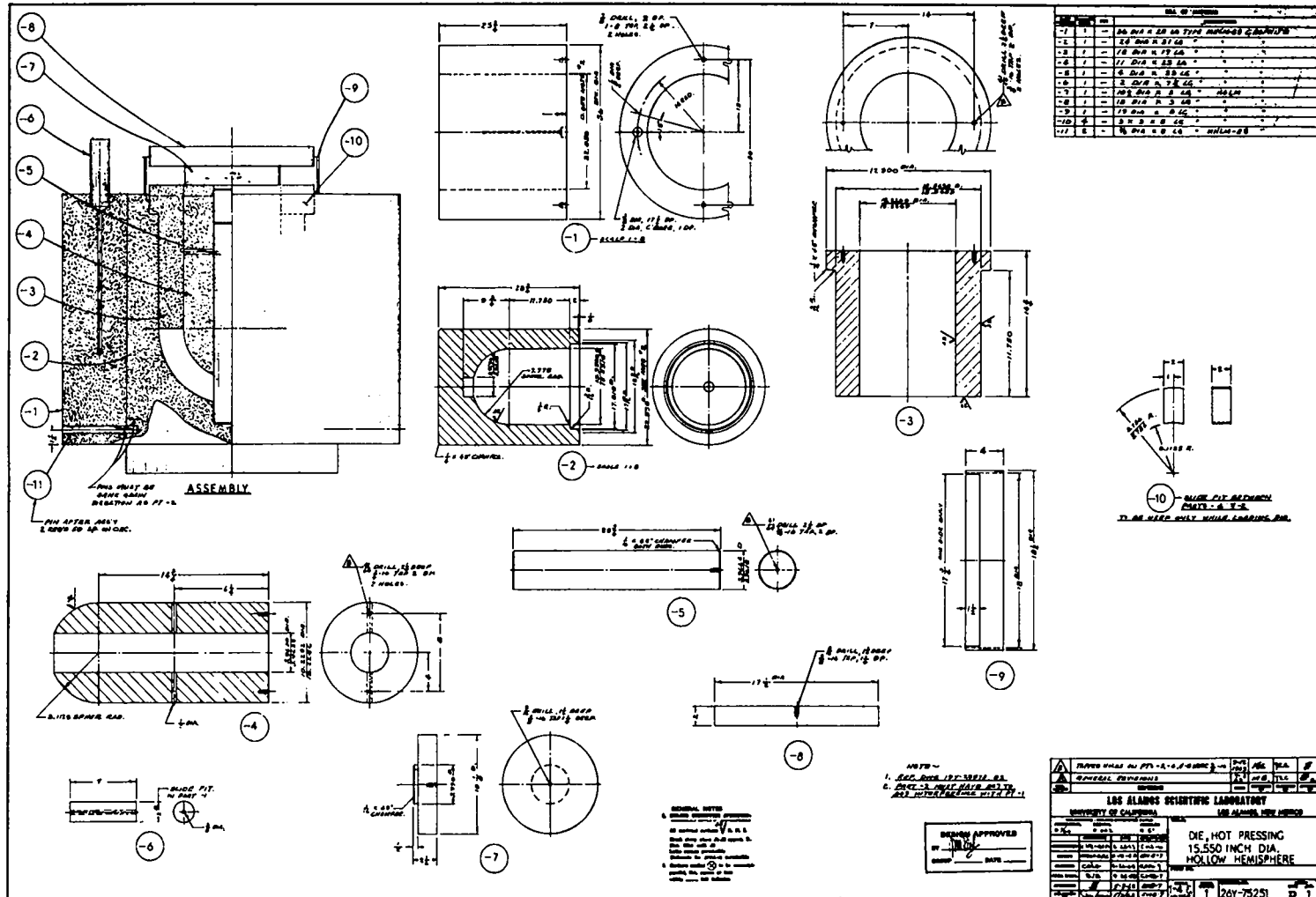

Figure 5 - Graphite Die Assembly for Pressing Hemispheres

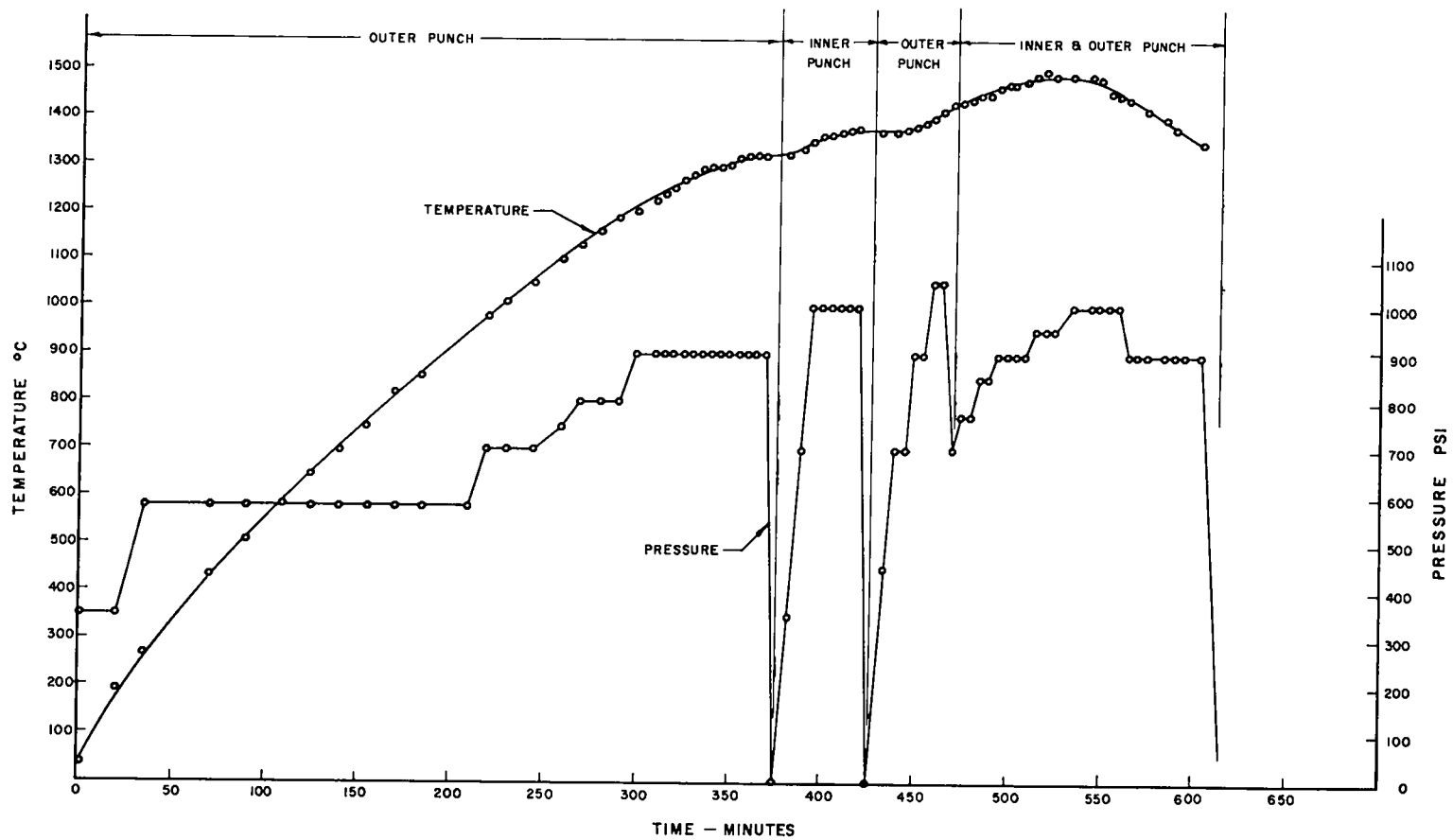

Figure 6 - Pressure-Temperature Cycle for 15.50-in.-Diameter WC-Co Hemisphere

Pressure on this outer punch was increased to 900 psi and held until the required movement occurred. The applied load was slowly reduced to zero. Measurements were made to determine the vertical relationship of the inner and outer punches, and the spacers were then manipulated to apply pressure on the inner punch.

An initial pressure of 350 psi was applied to this inner punch, and the pressure was slowly increased to 1000 psi and held until the required movement was obtained. The pressure was reduced to zero, and spacers were again manipulated to apply pressure on the outer punch after again determining vertical punch relationships.

Pressure was applied to the outer punch and slowly increased to a maximum of 1050 psi and held at this level until measured movement indicated that the inner and outer punches were flush. The gage pressure was then increased to provide a pressure of 700 psi on both punches simultaneously. The pressure on the punches was gradually increased to 1000 psi and held at this level until the movement stopped. The power input was reduced slowly, and the pressure was reduced to 900 psi. Power was turned off when the die cooled to 1430°C.

The die was disassembled by pressing the inner die case through the outer die case. The inner die case was sawed into two pieces, and the inner punch and center core were sawed at the equator of the pressed hemisphere. The remainder of the graphite adhering to the internal surfaces of the pressed piece was removed by drilling, sawing, and chiseling.

Hot Pressing of Cylinders

The two polar cavity cylinders 4.085 in. dia x 2.75 in. long were routinely hot pressed at 1430°C and 1350 psi to a density of 15.08 g/cc. According to normal procedures, the powder was loaded into the die, the loaded die assembly was positioned in the hot press, and the powder was cold pressed at 900 psi. The distance the punches extended out of the die was measured, the die assembly was reloaded into the hot press, and the die was surrounded by and covered with lampblack. It was inductively heated and the powder charge pressed according to the temperature and pressure cycle indicated in Figure 7.

DISCUSSION

Dies and Die Design

The thin ring, Figure 5, part 9, was employed to prevent the lampblack from falling into the exposed annular cavity at the early stages of the run and thus causing a false stop on the outer die punch at the termination of the run. The cutout in this ring was made to facilitate removal and changing of spacers during the hot press run.

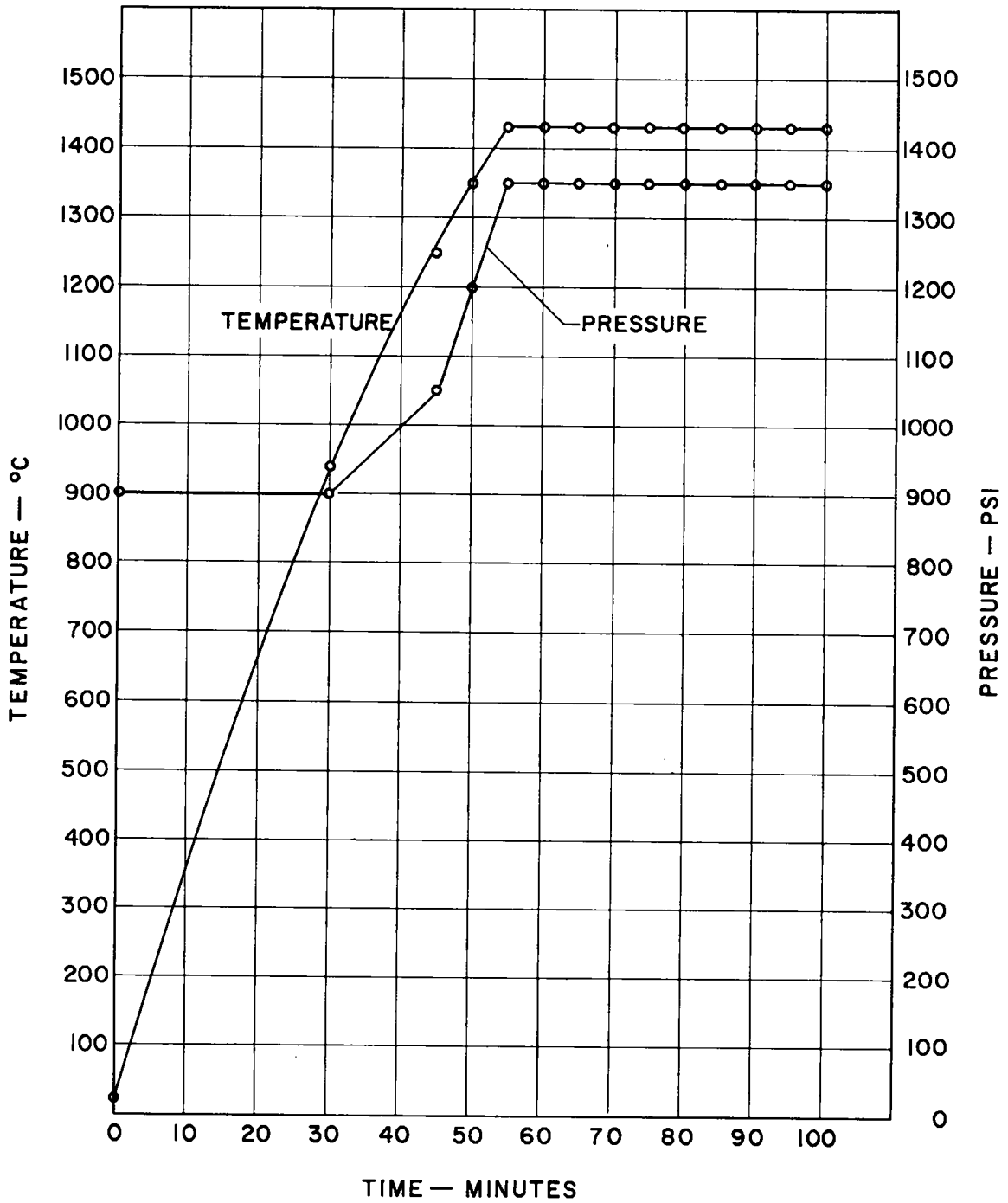

Figure 7 - Pressure-Temperature Cycle for 4.08-in.-
Diameter WC-Co Cylinder

The first hemisphere hot press run was terminated immediately prior to application of pressure simultaneously on both punches when a loud report announced a die fracture. Post-pressing examination of the ruptured die assembly revealed various defects in the graphite used for parts 1, 2, and 5 of Figure 5. The fractures did not occur through mechanically induced weak spots, i.e., drilled and tapped holes, thus essentially ruling out poor design as a cause of failure. Because the ATL graphite contained flaws, and because a machined and loaded die assembly represented a considerable investment in time and money, premium grade MHLM-85, a multiple impregnated, high-strength graphite was employed for succeeding assemblies. Only one outer case, Figure 5, part 1, was used for the two assemblies.

A very loud and sharp report was heard during the cooling cycle of hemisphere run number 2, and the pressure pump was immediately turned off. Subsequent examination revealed that a spacer below the inner die case had cracked in several places.

Temperature Measurement

Thermocouples were inserted in the 1/8-in.-dia x 2-in.-deep holes in the inner and outer cases at a 1 in. radial distance from the interface of the cases to determine the temperature lag in the inner case. Chromel-Alumel thermocouples were employed to minimize effects of the inductive field on the thermocouple readings. It was necessary to electrically ground the die assembly to minimize ac feedback to the potentiometer.

Figure 8 is a plot of the temperature readings obtained in the inner and outer graphite cases during the second hemisphere hot pressing. After the last thermocouple reading at 872°C, the thermocouples were removed, and subsequent temperature measurements were conventionally made with a Leeds and Northrup optical pyrometer.

The temperatures recorded in the temperature-pressure profiles in Figures 6 and 7 are those obtained by optical measurements.

Inspection and Sampling

Weight losses occurring during the hot pressing were 1.5 w/o and 1.4 w/o for the two hemispheres and 1.5 w/o for the two cylinders. The weighed hemispheres were submitted to the Shops Department for inspection. The measured O.D. of the first hot pressed hemisphere was, on the average, 0.018 in. smaller than intended, probably because the cooling cycle under pressure was terminated prematurely. Grinding stock at the equator averaged 0.040 in. for both hemispheres.

The hemispheres were shipped to a vendor for final grinding to drawing

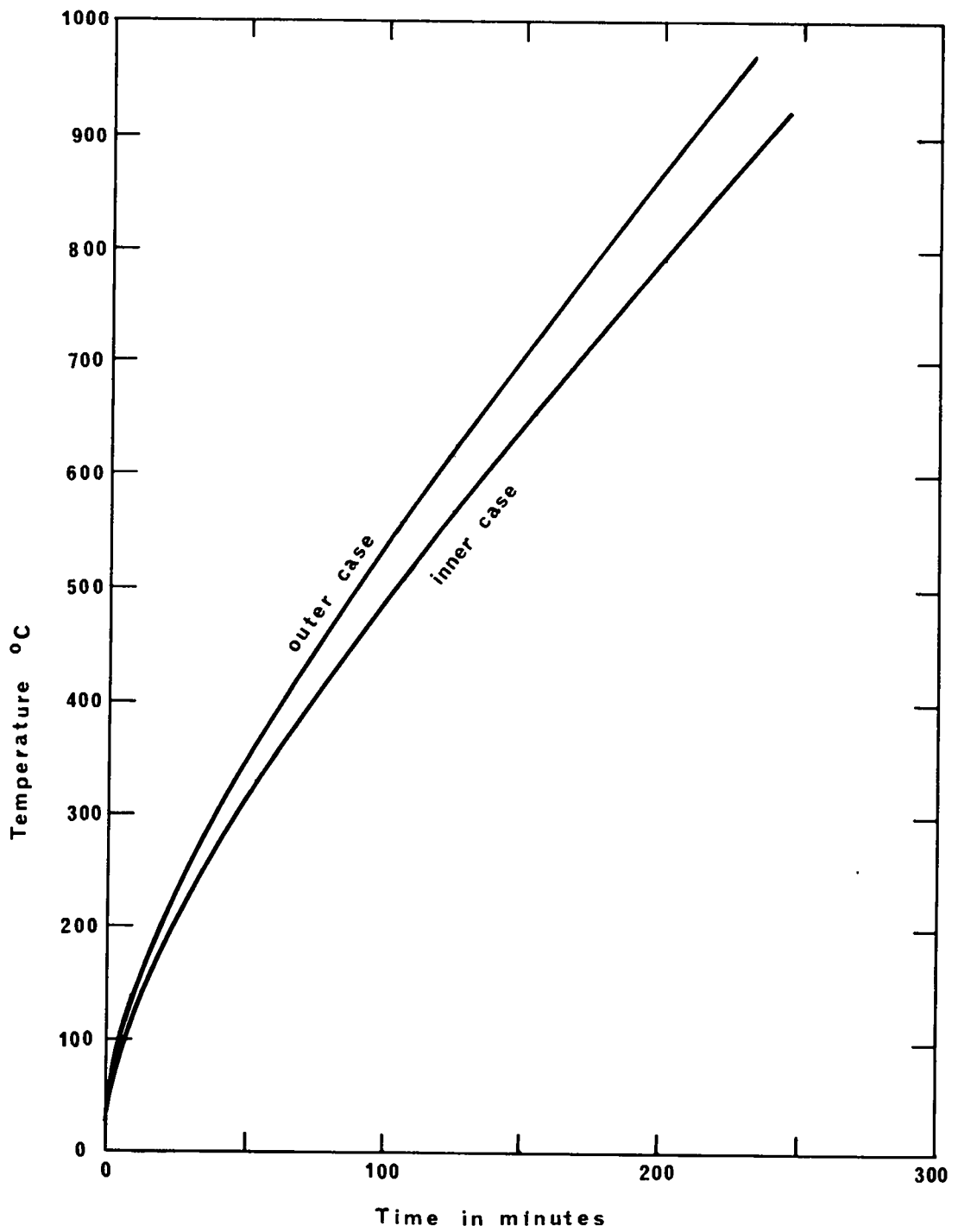

Figure 8 - Temperatures of Inner and Outer Graphite Die Cases. Run No. 2

specifications, and the cylinders were ground at IASL. The ground hemispheres were weighed and measured, and calculated densities were 15.08 g/cc for both.

Radiography and ultrasonic inspection of the hemispheres showed a uniform density and a flaw-free structure within the 0.040-in. W resolution of the 25-MeV Betatron.

A 0.64-in.-dia hole in the second hot pressed hemisphere was cored by spark machining. The core location (Figure 1) was in an area expected to be the lowest density and least uniform because the flow of powder there during the hot pressing would be minimal. Radiographic die penetrant, and ultrasonic inspection of the core indicated that it was flaw-free and uniform in density. The core was sectioned to provide samples near the outside and inside walls of the hemisphere and in the center of the wall thickness. These samples were examined metallographically, and the material adjacent to them was analyzed chemically.

The core samples analyzed 5.0 and 4.9 w/o Co. A portion of the core yielded at 585,000 psi in a compression test. Figure 9 shows photomicrographs of the core samples taken near the outer wall, center, and inside wall, respectively, indicating no intergranular porosity and very little porosity in the WC grains. The structure is similar to those reported in the literature for hot pressed WC-Co material.

RESULTS

Two 15.53-in.-O.D. x 10.20-in.-I.D., 366-lb hollow hemispheres with 3.95-in. polar cavities, and two 4.08-in.-dia x 2.74-in.-long cylinders of WC-6 w/o Co were hot pressed successfully to 99.9% of theoretical density and very close to design dimensions.

Nondestructive testing, chemical analysis, and metallographic examination indicated that the hemispheres were very uniform in density, composition, and structure and contained no detectable flaws.

Figure 10 shows a hemisphere in the as hot pressed condition, and Figure 11 shows a ground hemisphere.

The principal difficulty encountered in the fabrication of these components was the fracture of the first graphite die assembly for hemisphere hot pressing. This fracture was attributed to flaws in the graphite.

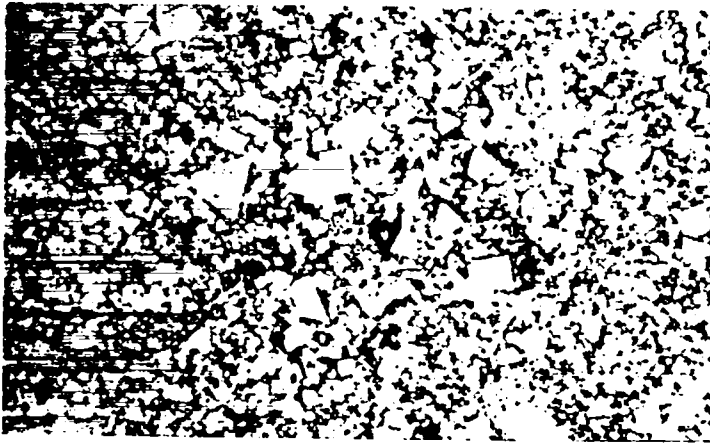

Structure Near
Outer Wall
750X

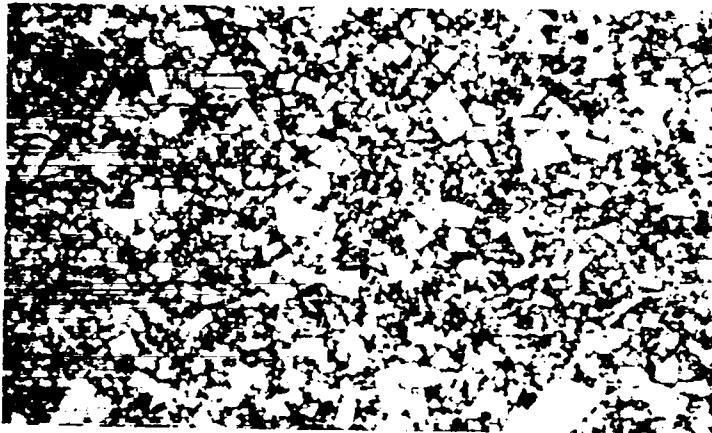

Structure Near
Center
750X

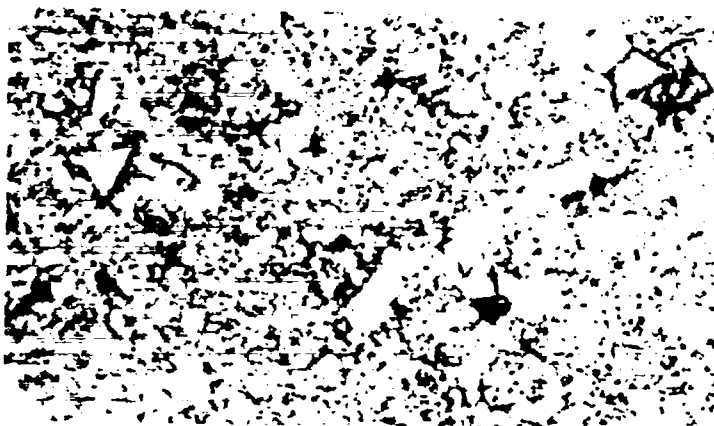

Structure Near
Inner Wall
750X

Figure 9 - Photomicrographs of Core Samples



Figure 10 - As Hot Pressed Hollow Hemisphere with
Polar Cavity

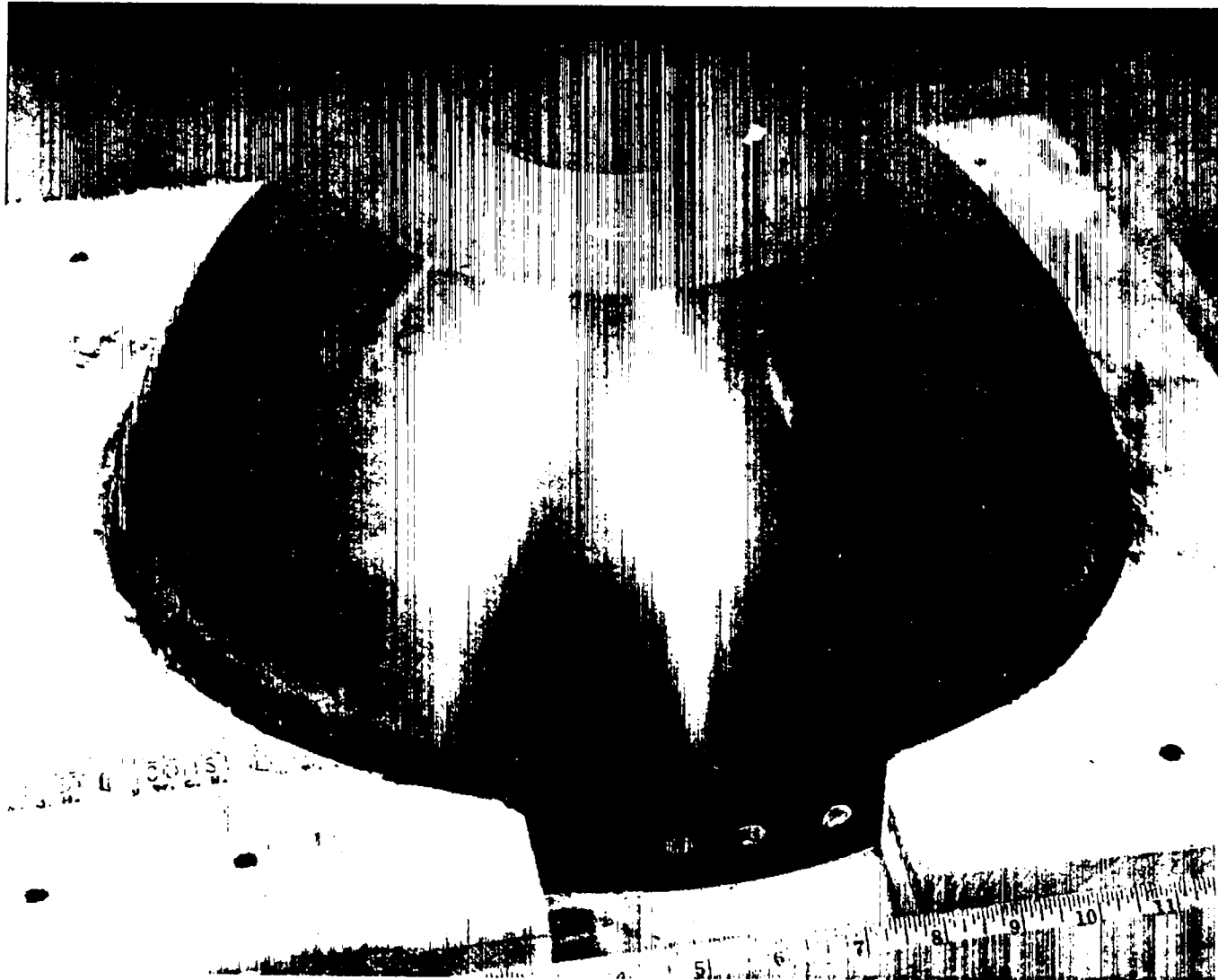

Figure 11 - Finish-Ground Hollow Hemisphere with Polar Cavity